



# Hand Glazer HG & HGEZ

## Operator's Manual and Technical Supplement

Belshaw Bros., Inc.  
814 44th Street NW, Suite 103  
Auburn, WA 98001 USA  
Tel: (206) 322-5474  
Fax: (206) 322-5425  
Toll Free (US): 1-800-578-2547  
E-mail: [service@belshaw.com](mailto:service@belshaw.com)  
[www.belshaw.com](http://www.belshaw.com)





# HG & HG EZ Glazers

## Standard & Under Counter

### Operator's Manual

Belshaw Bros., Inc.  
814 44<sup>TH</sup> ST NW Suite 103  
Auburn, WA 98001 USA  
Phone: (206) 322-5474 • Fax: (206) 322-5425  
Email: [service@belshaw.com](mailto:service@belshaw.com) • <http://www.belshaw.com>



**If you accept the machine from the shipping company, you are, in effect, saying that the machine is in good condition, and you must pay for the machine.** The freight company has accepted responsibility for the safe delivery of our machines. **For your protection**, inspect the machine to see that no parts are bent, scratched, or otherwise damaged. If any damage has occurred in shipping, file a freight claim with the shipping company immediately.

**IMPORTANT**

**Keep this manual for future reference.**

**EQUIPMENT RECORD**

Please provide the information below when you correspond with us about your machine.

Purchased by \_\_\_\_\_

Installed by \_\_\_\_\_

Date of installation \_\_\_\_\_ Model number \_\_\_\_\_

Serial number \_\_\_\_\_

020408

MN-1752EN

Belshaw Bros., Inc.

814 44th Street NW, Suite 103

Auburn, WA 98001 USA

Phone: (206) 322-5474 • Fax: (206) 322-5425

Email: [service@belshaw.com](mailto:service@belshaw.com) • <http://www.belshaw.com>



# Contents

<b>1</b>	<b><i>Operation</i></b>	<b>1</b>
<b>2</b>	<b><i>Cleaning</i></b>	<b>2</b>
	Cleaning the glazer	2
	Cleaning the glaze applicator	2
<b>3</b>	<b><i>Maintenance</i></b>	<b>3</b>

# Preface

The HG/HGEZ is designed to glaze donuts on the top and sides. It creates an even distribution of glaze.

The HG/HGEZ is designed to be used on a level floor.

The HG/HGEZ, produces 0.0 dB(A) of equivalent A-weighted sound pressure at workstations. This has been determined because there is no machine operation. Operation of HG/HGEZ is by a human operator.

Thorough understandings of how to operate, clean, and maintain the HG/HGEZ safely will prevent production delays and injuries. The operator must work safely at all times, read and follow the instructions in this manual, and heed all warnings, including the following:

- Do not overfill the glaze kettle. If glaze overflows the kettle, it could cause someone to slip on the floor and be seriously injured.
- To avoid damaging the machine, never use force to assemble, disassemble, operate, clean, or maintain it.
- Be careful never to get glaze, water, or other materials on the floor. If anything does get spilled on the floor, clean the area immediately. Materials on the floor can cause people to slip or fall, resulting in serious injury or loss of life.
- To prevent damage to the kettle, never use a metal object to scrape the kettle use only a plastic or rubber bowl scraper.

There are no power switches; simply set a screen of donuts onto the screen support, then pass the glaze applicator over the donuts, either by hand using the HG customer-supplied scoop, or by the frame-supported applicator on the HGEZ. The glaze applicator is designed to give uniform glaze coverage to donuts. Any excess glaze will drain back into the reservoir.

### IMPORTANT

**Casters with brakes can be locked during operation to keep glazer stationary. DO NOT forget to unlock brakes on wheels after operation, as most bakery floors are very hard on rubber wheels.**

1. After the HG/HGEZ has been cleaned, pour glaze into the glaze reservoir section of the kettle. Kettle will hold a maximum of 80 pounds of glaze.
2. Place a screen of donuts on top of the screen support rods.
3. Standing at the opposite end of the drain in the kettle, use the glaze applicator as follows:

### HGEZ

- A. With glazer applicator resting on applicator frame over the drain end of the kettle, raise applicator frame so the applicator lowers into glaze and fills automatically.

- B. Allow the applicator to fill fully, then put applicator frame back down.
- C. Roll the glaze applicator along the applicator frame. Slowly move the applicator forward for complete coverage.
- D. Roll the applicator back and lower it into the glaze reservoir by lifting the applicator frame.
- E. Place the screen of finished donuts on the drip tray and allow it to drip.
- F. Leave the glaze applicator frame in an upright position with the applicator in the glaze reservoir while transferring screens of donuts on and off the screen support rods.

### HG

- A. With the scoop applicator resting in the scoop holder at the end of the kettle, fill the scoop full of glaze and move it over the donuts, making sure that all the donuts have been glazed. It may take more than one pass.
- B. Set the scoop back down into the scoop holder at the drain end of the glaze kettle.
- C. Place the screen of finished donuts on the drip tray and allow it to drip.

**Cleaning the glazer**

For your safety, observe the following warnings throughout the entire cleaning process.

**WARNING**

**Thoroughly clean and dry the floor if glaze, water, or other materials are spilled. Materials spilled on the floor can cause serious injury or loss of life.**

Once a day, clean as explained below:

1. Lift the screen support rod assembly out of the kettle and wash with mild soap and hot water.
2. HGEZ only: Remove applicator track frame from the kettle and wash with mild soap and water.
3. Lift the kettle and drip tray off the frame and wash both with mild soap and hot water.

**CAUTION**

**To prevent damage to the kettle, never use a metal object to scrape the kettle use only a plastic or rubber bowl scraper.**

4. Wash the glaze applicator using the instructions below.
5. Replace the kettle into the frame. Reinstall the applicator track frame. Replace the screen assembly support rods, and the applicator. Close the drain valve.

**Cleaning the glaze applicator****HGEZ**

To clean the applicator, the gate must be removed.

1. Lift the gate up and rotate it out. It may help to push on the gate tabs from the outside of the applicator while rotating the gate.
2. Remove the clamping knob so the rollers and shaft can be removed for cleaning. See Figure 3-1.
3. Clean the parts with mild soap and hot water and dry thoroughly.
4. Reassemble the glaze applicator using the instructions found in Section 1, Glaze applicator assembly.

**HG**

1. Clean the scoop with mild soap and hot water and dry thoroughly.

# 3

# Maintenance

The only maintenance required for the HGEZ and HG is keeping it clean, and putting mineral oil on the O-ring for the drain plug (HGEZ).

Use the parts list found in the Appendix when new parts are needed.



# HG & HG EZ Glazers

Standard & Under Counter

Technical Supplement

Belshaw Bros., Inc.

814 44<sup>TH</sup> ST NW Suite 103

Auburn, WA 98001 USA

Phone: (206) 322-5474 • Fax: (206) 322-5425

Email: [service@belshaw.com](mailto:service@belshaw.com) • <http://www.belshaw.com>



**If you accept the machine from the shipping company, you are, in effect, saying that the machine is in good condition, and you must pay for the machine.** The freight company has accepted responsibility for the safe delivery of our machines. **For your protection**, inspect the machine to see that no parts are bent, scratched, or otherwise damaged. If any damage has occurred in shipping, file a freight claim with the shipping company immediately.

To transport the HG/HGEZ Glazer to the workstation and unpack it:

1. Use a forklift to transport the shipping crate to the workstation.
2. Break down the shipping crate.
3. Remove all the packing materials from the fryer, including foam, tape, brown paper, plastic, and white protective coating.

### IMPORTANT

**Keep this manual for future reference.**

### EQUIPMENT RECORD

Please provide the information below when you correspond with us about your machine.

Purchased by \_\_\_\_\_

Installed by \_\_\_\_\_

Date of installation \_\_\_\_\_ Model number \_\_\_\_\_

Serial number \_\_\_\_\_

03/19/08

MN-1753EN

Belshaw Bros., Inc.

814 44th Street NW, Suite 103

Auburn, WA 98001 USA

Phone: (206) 322-5474 • Fax: (206) 322-5425

Email: [service@belshaw.com](mailto:service@belshaw.com) • <http://www.belshaw.com>



# Contents

<b>1</b>	<b>Installation</b>	<b>1</b>
<b>2</b>	<b>Appendix</b>	<b>4</b>
	Drawing Insert Page	Insert

# Preface

The HG/HGEZ is designed to glaze donuts on the top and sides. It creates an even distribution of glaze.

The HG/HGEZ is designed to be used on a level floor.

The HG/HGEZ, produces 0.0 dB(A) of equivalent A-weighted sound pressure at workstations. This has been determined because there is no machine operation. Operation of HG/HGEZ is by a human operator.

Thorough understandings of how to operate, clean, and maintain the HG/HGEZ safely will prevent production delays and injuries. The operator must work safely at all times, read and follow the instructions in this manual, and heed all warnings, including the following:

- Do not overfill the glaze kettle. If glaze overflows the kettle, it could cause someone to slip on the floor and be seriously injured.
- To avoid damaging the machine, never use force to assemble, disassemble, operate, clean, or maintain it.
- Be careful never to get glaze, water, or other materials on the floor. If anything does get spilled on the floor, clean the area immediately. Materials on the floor can cause people to slip or fall, resulting in serious injury or loss of life.
- To prevent damage to the kettle, never use a metal object to scrape the kettle use only a plastic or rubber bowl scraper.

# 1

# Installation

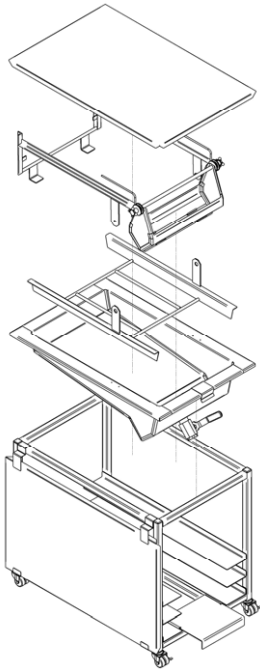

Figure 1-1. Exploded view of HG18EZ.

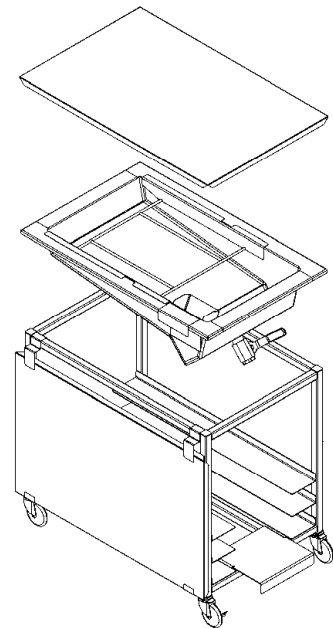

Figure 1-2. Exploded view of HG.

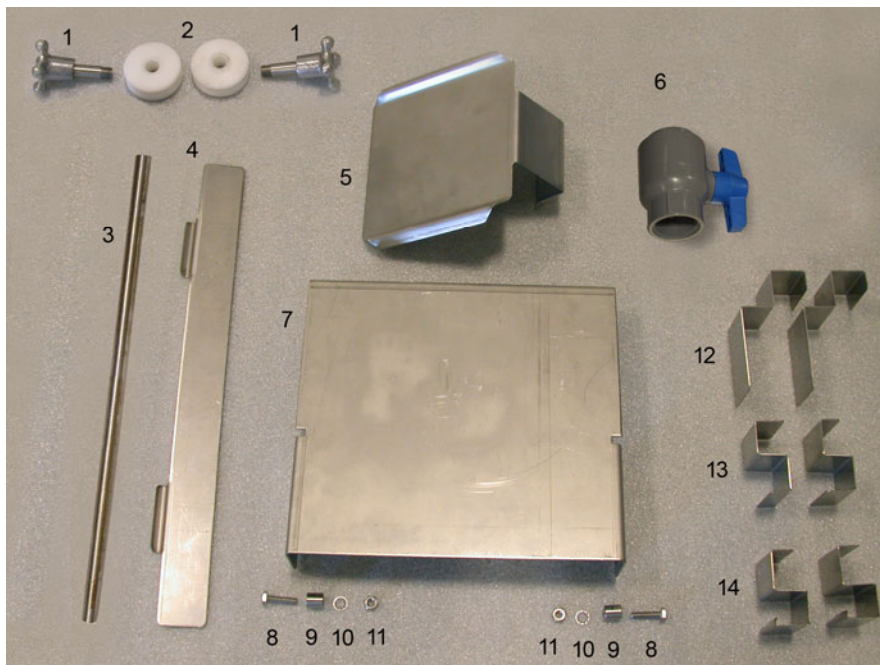

Figure 1-3. Parts view.

Refer to photos and assembly drawings as needed. Numbers in ( ) refer to Figure 1 unless otherwise noted.

1. Unpack the Glazer completely and wash all parts with mild soap.
2. Place the cover brackets (12 & 13) on one side of the frame. Item 12 hangs on the top rail of the frame underneath the edge of the kettle. Item 13 hangs on the lower rail of the frame.
3. Install the kettle into the frame with the glaze trough over the braking casters.
4. Screw the drain (6) onto the bottom of the kettle drain hole. Make sure it is closed.
5. Snap the glaze diverter (5) on the edge of the glaze trough, in the center.
6. Place the screen support into the kettle; the long side supports toward the glaze trough.



Figure 1-4. Applicator frame connector.

7. HGEZ: Mount the applicator frame on top of the kettle, inserting the two "buttons" on the applicator frame into the holes on the screen support (Figure 1-4).
8. Assemble the glaze applicator.
  - a. The handles (1), rollers (2), and shaft (3) are attached to the top of the glaze applicator. See Figure 1-5.
  - b. Install the applicator gates (4) by inserting the tabs, curving upwards, into the applicator slots from the inside and rotating to hold in place.

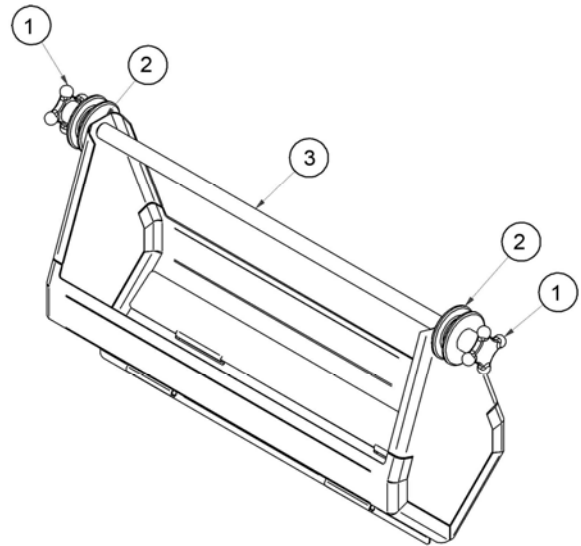

Figure 1-5. HGEZ Glaze applicator

9. HGEZ: Put the glaze applicator on the applicator frame, making sure it glides smoothly on the rails.
10. Hang the lower drain tray brackets (14) on the opposite side as the cover brackets (side drain tray) or on the end away from the glaze trough (end drain tray).
11. Hook the drain tray onto the upper frame above the brackets.
12. Install the drain tray support rod. Insert the cross bar of the rod into the lower brackets and hook the ends into the desired hole on the bottom of the drain tray (Figure 1-6).



Figure 1-6. Drain tray hook.

13. Install the Bucket Support.

- a. Place the bucket support tray (7) on the lower frame under the glaze trough. See main assembly diagram.
- b. Attach the bolts (8), spacers (9), lock washer (10), and nut (11). Slide the bolt from the outside of the tray, placing the spacer, washer, and nut on the inside to secure it in place. See Figure 1-7.



Figure 1-7. Bucket support fasteners.

14. Slide the cover into the cover brackets for storage.

# 2

# Appendix

See the Parts List Drawing Insert Page.