

Belshaw Adamatic

## BARO-1E Single Rack Oven, Electric

### Construction features

- Heavy-duty stainless steel interior
- Oversized low watt-density heater elements
- Cooking compartment insulated with 5" thick high-temp insulation
- Fully integrated hood with single point exhaust connection
- Automatic, heavy-duty "B" style lift and rotate system
- Heavy-duty gear driven rotation system
- Cooking chamber illuminated by externally mounted florescent lamp
- Heavy-duty door with 9.75" x 57.5" viewing window
- Interior door safety release mechanism
- Accommodates one single side-load or end-load rack

### Performance Features

- 200°-550°F / 93°-288°C temperature range
- Low watt-density elements operate at lower temperatures for extended life
- High volume gravity feed, waterfall type steam system
- Adjustable air circulation louvers
- Self adjusting slip clutch protects operator and prevents component damage
- Automatic rack stop and lower when door is opened
- Floor level loading without ramps

### Integrated Hood Features and Performance

- Meets the requirements of NFPA 96 & UMC requirements for Type I & II Hoods
- 20 Ga stainless steel body
- Fully welded construction
- Single 8" round collar, Velocity: 2,300 FPM @ 800 CFM
- 4.5 sq ft of capture area, filter velocity of 120 FPM, 0.03" wc@530 CFM

### Controls Package



- Digital controls with large LED readouts for Time and temperature
- Large LCD event screen for programming and oven status
- 60 Item programmable memory, with 5-events per item
- Simple manual program for time, temp., steam and vent
- Infrared port for uploading and downloading programs
- Flash type programming for revision updates without replacing PCB

### Options

- Prison package



BARO-1E Rack Oven

|  |
|--|
| <p><b>Rack Capacity</b></p> <p>1 single side-load or end-load rack</p>   |
| <p><b>Short Bid Specification</b></p> <p><b>Rack Oven Model BARO-1E</b> shall be a 41kW electrically heated rotating, single rack capacity unit with: oversized low density heating elements; gravity feed waterfall type steam generation system; 5" thick compartment insulation rated at 0" combustible wall clearance; heavy-duty rack lift and rotate system with gear driven rotation system; simple solid state controls, with digital time-temperature readouts, 5 event menu programs for time, temperature, steam, vent and blower function, 60-menu program memory; an integrated hood meeting NFPA 96 and Type I &amp; II construction standards, plus all the features listed</p> |
| <p><b>Standard Product Warranty</b></p> <p>One-Year Parts and Labor, USA and Canada.<br/>(USA includes 50 states + DC unless specified)</p>  |
| <p><b>Certifications</b></p> <p> </p>  |

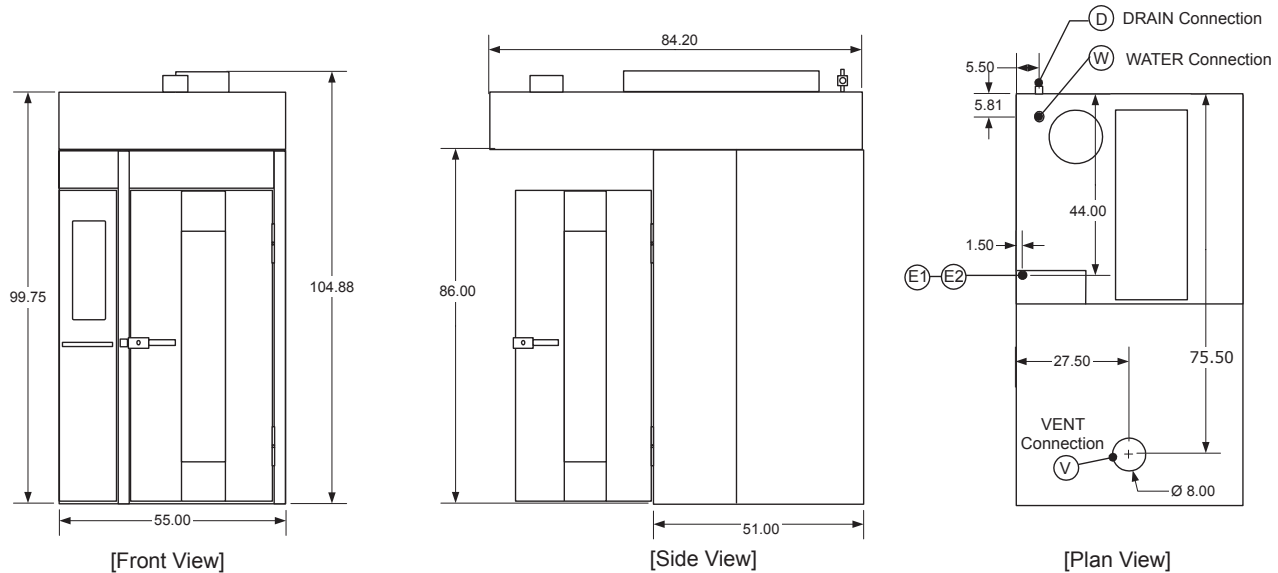

**Dimensions**

|                                |                      |
|--------------------------------|----------------------|
| Overall width                  | 55" (1397 mm)        |
| Overall height                 | 104.5" (2654 mm)     |
| Overall depth (inc. hood)      | 88.2" (2240 mm)      |
| Depth at floor (not inc. hood) | 51" (1295 mm)        |
| Clearance required             | 0" sides and back    |
| Net weight                     | 2500 lbs (1537 kg)   |
| Shipping weight                | 2900 lbs (1318 kg)   |
| Crate size (1 crate)           | 113"L x 62"W x 64" H |
| Crate volume                   | 260 cu. ft.          |
| Freight Class                  | 70                   |

**Electrical**

|           |                |       |        |
|-----------|----------------|-------|--------|
| 120V-60-1 | E-1 connection | 12 A  | 1.5 kW |
| 208V-60-3 | E-2 connection | 113 A | 41 kW  |
| 240V-60-3 | E-2 connection | 98 A  | 41 kW  |
| 480V-60-3 | E-2 connection | 49 A  | 41 kW  |

Two electrical connections

- E1 on diagram: For Controls/Lift and rotate: 1/2" EMT, 120 VAC 1-Phase
- E2 on diagram: For circulation blower and heaters 1-1/4" EMT, 208-240V or 480V 3-Phase

**Installation Requirements**

- Requires on-site installation
- KD shipment in one piece. When disassembled, can fit through 36" opening
- Consult factory for shipment fully assembled
- 112" Floor to ceiling height required for tip-up
- Non-combustible floor supported by non-combustible structure
- Zero clearance required from combustible surfaces on sides and back

**Ventilation**

- 8" Round vent collar (consult local codes for installation requirements)
- 530 CFM Roof vent (not included)

**Water Supply & Drainage**

- Supply: 1/2" NPT (9 GPM@40 psi)
- Drain: 3/4" NPT (210°F, 1 GPM) vented
- Line to be dropped from ceiling
- Connection will be located 100" above finished floor, 5.5" from the left side of the oven, 6" from the rear of the oven
- Oven comes pre-installed with water pressure regulator, water pressure gauge, water solenoid and shut-off valve
- Your local water conditions may damage your appliance. Failure to properly treat water may result in damage and may void your warranty. Ensure that your water supply meets these minimum water quality specifications:
  - Alkalinity: 22 ppm
  - Aluminum: 17 ppm
  - Calcium: 3.3 ppm
  - Free chlorine residual: 0.6 ppm
  - Magnesium: 0.65 ppm
  - PH range: 8.5 s.u.
  - Sodium: 8.5 ppm
  - Total Hardness: 11.9 ppm
- Consult your local water treatment company for proper water filtration system.