



Above: Snack Master frying system with fryer, filter, support table and receptacle bin.

- ★ **For restaurants, bars, supermarkets, convenience stores and anywhere fresh food is consumed**
- ★ **Includes fryer, support table, and filtering system**
- ★ **Customers can watch, sample, and buy – hot 'n fresh**
- ★ **For tortilla chips, chicken nuggets, mozzarella sticks, falafel and more**
- ★ **No standing over an open fryer**
- ★ **Capacity approx 140 lbs (64 kg) tortilla chips per hour**
- ★ **Compact footprint 72" x 32"**

Belshaw Adamatic Bakery Group's Snack Master automated frying system produces fresh tortilla chips, chicken nuggets, mozzarella sticks and other similar products. The frying system can be put on view to encourage sample tasting and on-the-spot purchases. No specific skills are required to operate the system. The operator fills the entry chute, and a consistent finished product exits at the other end. The submerging conveyor guides the chips between two conveyor belts through the length of the fryer under the surface of the oil. An exit conveyor drops the chips into a basket or receptacle. The operator can top up frying oil using the filtering system's foot switch, while the fryer is running.

Features – Fryer

- Fast-recovery heating elements
- Removable conveyor
- Close weave conveyor belting
- Tilt up elements for cleaning kettle
- Thermostat control
- Variable speed, from 1 - 7 Min frying time
- Oil refill indicator
- Emergency stop switch
- 3-phase power
- Oil drain and valve
- Stainless steel construction (some aluminum components)

Features – Filtering System

- Heavy duty stainless steel frame and casters
- Heavy duty pump & motor
- Fixed connection refill hose to fryer
- Detachable rinse hose with plated steel nozzle and safety grip
- Reusable long life synthetic filter
- Heavy duty, moisture repellent foot switch for pump
- Heating element and thermostat factory set to 200°F/93°C
- High-temperature limit switch
- Oil capacity 250 lbs (113 kg)

Features – Support Table

- Fold-down table extension
- Guide rails for filter system
- Lock down bolts for fryer
- All stainless steel

Production Capacity

- Approximately 140 lbs (64 kg) tortilla chips per hour.
- Notes:
 - Output depends on how fast the variable speed conveyor is set to run.
 - Fryer must be loaded regularly
 - When loaded regularly, a second person may be required to bag or otherwise handle the finished product.

Fryer dimensions

- Fryer length: 49" (1.25m)
- Fryer length with removable infeed chute in place: 56" (1.42m)
- Fryer width: 29" (74cm)
- Fryer height: 17" (43cm) with cover, not including exhaust vent)
- Oil capacity: 106 lbs (48 kg)

Overall system dimensions:

- Table length: 72" (1.83m)
- Table width: 32" (81cm)
- Overall system height: 43"-50" (1.09m-1.27m). Height depends on table leg adjustment up to 7" (18cm)

Electrical

- Fryer: 208/240V-60-3, 70 Amps (5-wire)
- Filter: 208V-60-1, 20 Amps

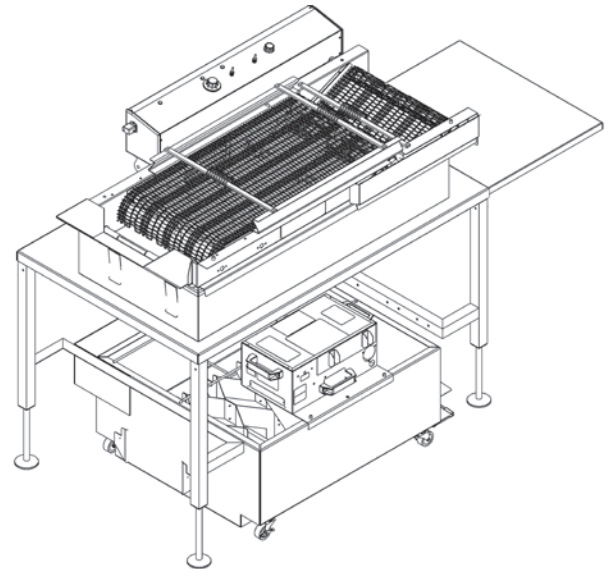

Note: Fryer includes cover not shown in diagrams.

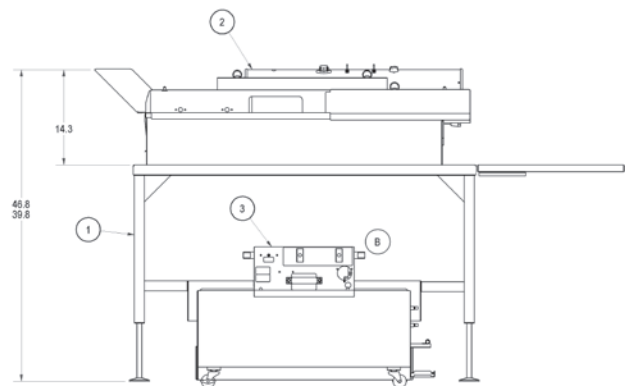
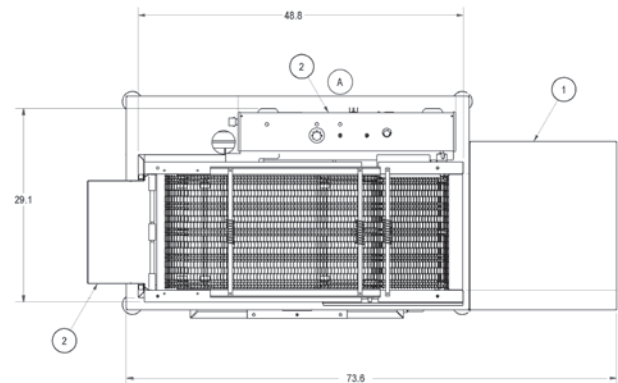

EQUIPMENT

- 1 FRYER TABLE
- 2 MKVIDC FRYER, WITH CHIP CONVEYOR
- 3 EZ34 SHORTENING MELTER / FILTER

CONNECTIONS

- A FRYER: 208V, 60 HZ, 3 PH, 70 AMPS (5-WIRE)
- B EZ34 MELTER / FILTER: 208V, 60 HZ, 1 PH, 20 AMPS